

Electrodeposition of Alpha-Emitting Nuclides from Ammonium Oxalate-Ammonium Sulfate Electrolyte

Myung Ho Lee,* Cheol Ju Kim,[†] and Bong Hyun Boo^{‡,*}

Nuclear Environmental Research Division, Korea Atomic Energy Research Institute, Taejon 305-353, Korea

[†]Department of Chemistry, Chonbuk National University, Chonju 561-756, Korea

[‡]Department of Chemistry, Chungnam National University, Taejon 305-764, Korea and Center for Molecular Science, 373-1 Kusung-dong, Yusung-gu, Taejon 305-701, Korea

Received April 8, 1999

A method is described for electrodeposition of the alpha-emitting nuclides. The effects of electrolyte concentration, chelating reagent, current, pH of electrolyte, and the plating time on the electrodeposition have been investigated in an ammonium oxalate-ammonium sulfate electrolyte containing diethyl triamino pentaacetic acid in order to determine the optimum condition to plate plutonium. An optimized electrodeposition procedure for the determination of plutonium was validated by application to IAEA-Reference soils. The chemical yield in the optimized method for electrodeposition step in the environmental sample was about 7% higher than that of a Talvitie's method. The electrodeposition procedure developed with a ²⁴²Pu tracer was also applied to analyze the actinides such as thorium, uranium, and americium.

Introduction

Electrodeposition, as a final step of radiochemical analysis procedure, plays an important role in both purification and preparation of counting sources providing an uniform and adherent source for high resolution alpha spectrometric measurement. Plutonium, americium, and higher actinides are frequently plated from the solutions of ammonium sulfate,¹⁻⁴ ammonium chloride,⁵⁻⁶ ammonium chloride-ammonium oxalate,⁷ and dimethylsulfoxide.⁸ The most widespread method for electroplating actinides is that described by Talvitie,⁹ using ammonium sulfate as an electrolyte in the plating solution.

This method can be applied to analyze samples with a relatively simple matrix composition, such as tracer solutions or water samples. However, difficulties are encountered when environmental samples with a complex matrix composition are to be analyzed. The final step of the separation procedure, the electroplating from an ammonium sulfate solution, is easily disturbed by traces of matrix elements which have not been completely removed in the separation procedure. Even a small amount of organic carbon will reduce the recovery significantly. Removal of organic carbon before electroplating by wet ashing with nitric acid or sulfuric acid is therefore strongly recommended. Therefore, the electroplating time needed for analysis of environmental samples is lengthened at least for 4 hours. An additional disadvantage of the method is the necessity of a precise pH adjustment in the electroplating solution. The use of ammonium hydroxide for pH adjustment may result in loss of Pu caused by polymerization, since hydrolysis of Pu(IV) can occur near the local dropping position of concentrated NH₄OH used in the initial pH adjustment. Recently, an alternative technique utilizing micro-coprecipitation with rare earths has been developed to overcome the difficulties involved in the electrodeposition and to provide sources for α -spectrometry.¹⁰⁻¹¹ Although this method is simple and

rapid compared with this electrodeposition method, the energy resolution (FWHM) is not higher than that in the electrodeposition.

In this study, a simple and quantitative technique was developed to overcome the disadvantages of the Talvitie's method for the electrodeposition of plutonium after radiochemical separation from environmental materials. The optimized method was validated by application to IAEA-Reference soils. The developed electrodeposition method has been applied to analyze the actinides such as thorium, uranium, and americium.

Experimental Section

Preparation of electrodeposition solution and cell. An electroplating solution used in this study was prepared as follows: 43 g ammonium oxalate, 53 g ammonium sulfate, 18 g hydroxylammonium sulfate, and 2 g diethyltriaminopentaacetic acid (DTPA) are dissolved in 1 L H₂O and then the pH is exactly adjusted to 1.8 with sulfuric acid.

The electroplating cell was made of teflon. Figure 1 describes the cell used in these experiments. The effective

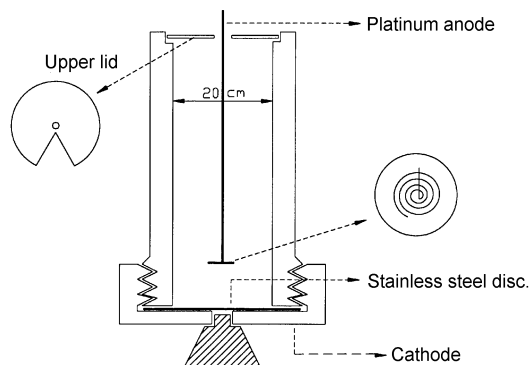

Figure 1. Schematic diagram of the electrodeposition cell.

area of electrodeposition was 3.14 cm². The anode was a polished platinum spiral wire. The upper lid, from which a small segment was cut out, was used not only to prevent release of the electrolyte outward but also to check visually the volume of the electrolyte inside the cell during the electrodeposition procedure.

The ²⁴²Pu, ²³²U, ²²⁹Th, and ²⁴³Am tracers with high alpha purities were obtained from Isotope Products Laboratories, USA. Radioisotope dilution was made for these samples.

Electrodeposition procedure. 1. Add the Pu fraction obtained after the separation and cleaning procedure, which contains about 500 dpm ²⁴²Pu tracer, to a 50 mL crystallizing dish, and then evaporate it on a sand bath slowly to near dryness;

2. Rinse the crystallizing dish with a 3 mL electroplating solution and transfer the rinsing solution into an electrodeposition cell;

3. Wash the crystallizing dish twice with a 3 mL electroplating solution and transfer it into the cell;

4. Adjust the distance between the two electrodes to about 5 mm;

5. Turn on power for 2 hours and then adjust the current to 950 mA;

6. Add about 1 mL conc. NH₄OH to the cell before the end of electrodeposition;

7. Rinse the stainless steel plate with water and alcohol, and hold it for 30 seconds in the flame of a Bunsen burner.

Alpha spectrometric system. The alpha spectrometer (EG&G ORTEC, Model 676A) includes an ion-implanted silicon detector (ORTEC, size: 450 mm²; alpha resolution : 25 keV FWHM at 5.486 MeV of ²⁴¹Am) in a vacuum chamber (Edwards Model E2M8), a detector bias supplier, a preamplifier, a linear amplifier, and a multichannel pulse-height analyzer. During the measurement, the pressure of the chamber was maintained at 10⁻² Torr.

As shown in Figure 2, an increase of the sample-detector distance gives rise to a decrease in the counting yield. In this study, the sample-detector distance was fixed at 10 mm, because the detector is apt to be contaminated by recoil effects in the case of a shorter distance between the sample

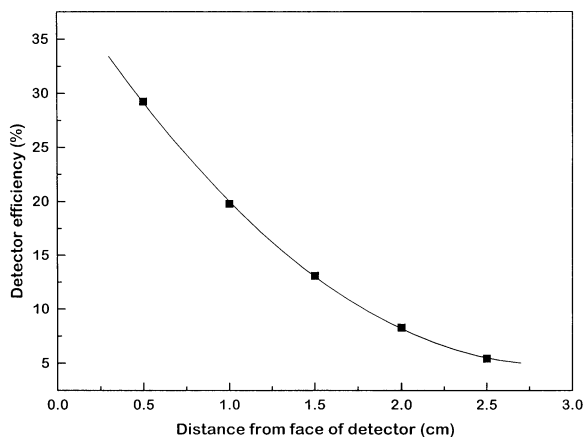

Figure 2. Alpha counting efficiency vs. the source-to-detector distance.

and the detector.

Radiochemical analyses of ^{239,240}Pu and ²³⁸Pu in environmental samples. For an accurate measurement of ^{239,240}Pu and ²³⁸Pu by alpha-particle spectrometry, firstly, a plutonium fraction free from major matrix components such as silica, iron, or aluminum, and from other alpha-emitters is required. Secondly, a suitable method to prepare the source for alpha spectrometry is necessary. Pu is leached by aid of mineral acids from the ashed sample material (100 g of soil and sediment; 20 g of moss) and separated from most matrix components by extraction with a TOPO (trioctyl phosphineoxide) solution in cyclohexane.¹² After back extraction of the Pu fraction with ascorbic acid/hydrochloric acid, trace elements and disturbing alpha-emitting radionuclides of natural or man-made origin are separated radiochemically by coprecipitation of the Pu with lanthanum fluoride and by an anion-exchange step. Finally, the purified Pu fraction is electrodeposited on a polished stainless steel disc¹³ and measured by α -ray spectrometry. The chemical yields attained by this analytical procedure were in the range 70-80%. The detection limit was calculated from reagent blanks data using the following equation:¹⁴

$$LD(Bq/kg) = \frac{(k_{1-\alpha} + k_{1-\beta}) \cdot [2C]^{1/2}}{T \cdot E \cdot Y \cdot M}$$

where $k_{1-\alpha}$, $k_{1-\beta}$ refers to degree of confidence from Gaussian equation (at the 95% confidence level: $k_{1-\alpha} = k_{1-\beta} = 1.645$),

C to background counts in the region of interest (ROI),

T to background counting time,

E to counting efficiency,

Y to chemical yield,

M to mass (kg).

The detection limit was found to be 0.0063 Bq/kg-dry for soil and sediment, and 0.031 Bq/kg-dry for moss in 86000 seconds of counting time in the alpha spectrometry.

Results and Discussion

Modification of the electrodeposition step. Determination

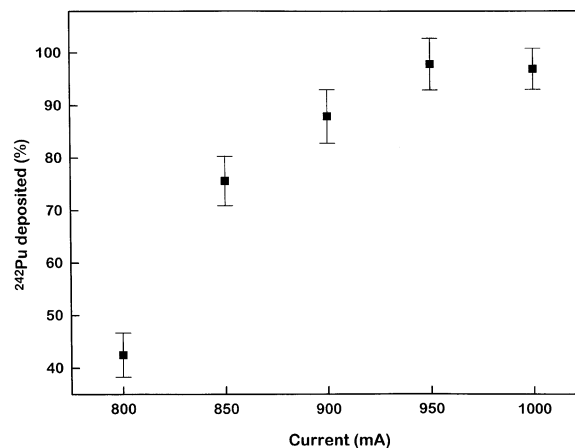

Figure 3. Variation of the deposition yield of ²⁴²Pu with cell current.

of the optimum conditions for plating plutonium requires the investigation of the effects of parameters such as plating time, current, electrolyte concentration, chelating reagent, pH, and volume of electrolyte on the electrodeposition of plutonium. In this study, the effects on the electrodeposition were investigated in the ammonium oxalate-ammonium sulfate electrolyte.

The effect of the current at a fixed electrodeposition time (2 hours), volume (9 mL), and pH (1.8) is shown in Figure 3. The maximum yield was achieved at a current of 950 mA. Figure 4 shows how plating yields vary with pH at constant electroplating time (2 hours), current (950 mA), and volume (9 mL). The pH value was controlled with 0.1 M H₂SO₄ and NH₄OH. The results shown in Figure 4 indicate that the optimum pH is 1.8. Also, the effect of the plating time at fixed current (950 mA), volume (9 mL) and pH (1.8) is shown in Figure 5. The low deposition yield of ²⁴²Pu within 1 hour was due to the change of pH of the electrolyte during the deposition. As seen in Figure 5, the pH at the cathode was varied over a wide range with the plating time. At the high current (950 mA) used in this procedure, most of protons from the strong acid (H₂SO₄) are discharged at the beginning of the deposition at a faster rate than it can be replaced from the weak acid such as ammonium oxalate and ammonium

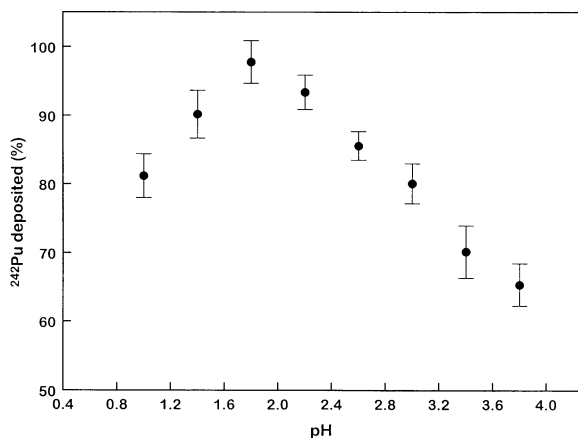

Figure 4. Variation of the deposition yield of ²⁴²Pu with the cell pH.

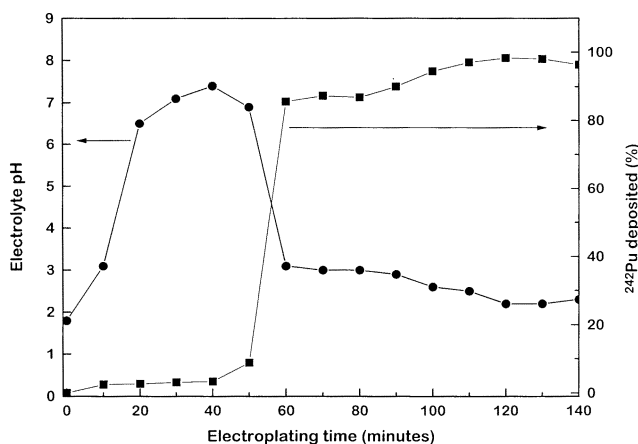

Figure 5. Variation of the deposition yield of ²⁴²Pu and the electrolyte pH with electroplating time.

sulfate or than oxidation of water. Such a discharge rate should account for the rapid increase of pH at the beginning of the deposition. However, after the deposition process is continued for about 1 hour, the pH decreases to about 3.0, and then after the deposition is continued for 2 hours, the pH stabilizes to 2.2 due to the role of the buffer. That is, the hydrogen ion concentration is contributed by dissociation of the weak acid or oxidation of water so that the pH decreases in the electrolyte. Therefore, the optimum deposition time was found to be 2 hours. When the electrolysis is continued for over 2 hours, the deposit tends to redissolve due to an increase in acidity and concentration of the electrolyte.

In general, a chelating agents such as NTA (nitrilotriacetic acid), EDTA (ethylenediaminetetraacetic acid), and DTPA have a good acid solubility, and prevent polymerization and hydrolysis during the electrodeposition. Puphal and Olsen⁷ have used DTPA to improve the yields of several nuclides in the electrodeposition. However, if one uses the Puphal and Olsen's method, the electrodeposition must be performed in a fume hood because of evolution of chlorine during the electrodeposition. Also, chloride-containing electrolyte is apt to etch the stainless steel cathode if it contacts the steel for any length of time before the electrodeposition. DTPA as a chelating agent was added to ammonium oxalate-ammonium sulfate electrolyte to overcome this shortcoming of the Puphal and Olsen's method. In this experiment, the DTPA concentration was varied from 0.002 to 0.007 M. Other parameters were fixed as described above. Figure 6 shows variation of the plating yields with the DTPA concentration at constant volume. The deposition yields of the ²⁴²Pu were varied from 85% to 98%. The maximum yield was obtained at a 0.005 M DTPA concentration.

At optimum conditions, the ammonium oxalate concentration was varied over a wide range as seen in Figure 7. There was corrosion of the cathode and discoloration of the electrolyte in the absence of ammonium oxalate. Also, spattering and frothing occurred at ammonium oxalate concentrations greater than about 0.7 M. The ammonium sulfate concentration in the range of 0.3–0.8 M results in good yields at all the levels. Below 0.3 M, the reduction in current to prevent boil-

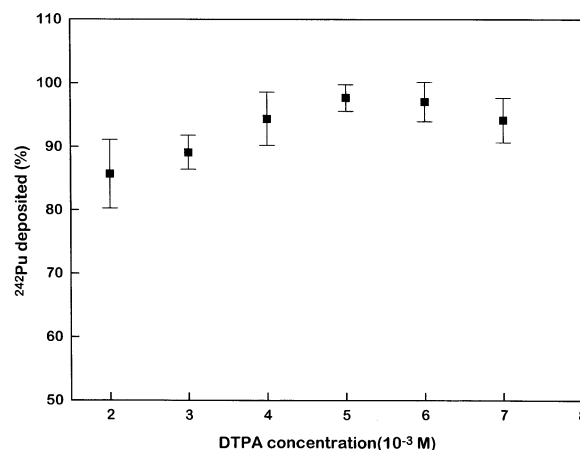

Figure 6. Variation of the deposition yield of ²⁴²Pu with DTPA concentration.

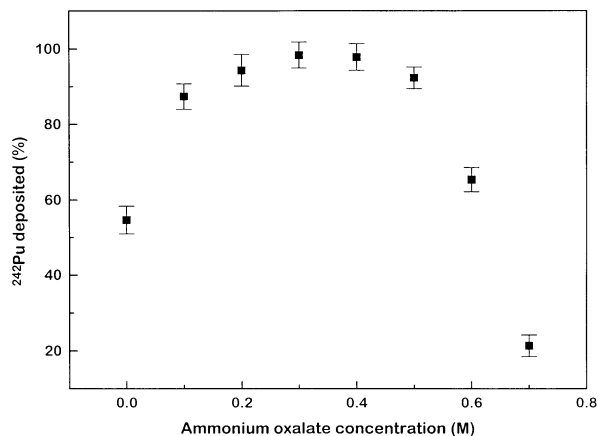

Figure 7. Variation of the deposition yield of ²⁴²Pu with ammonium oxalate concentration.

Table 1. Optimum conditions of electrodeposition

Anode	Platinum wire, 1 mm dia.
Cathode	Stainless steel disk
Current	950 mA
Volume	9 mL
Duration of electrodepos.	2 hours
Electrolyte solution	0.3 M ammonium oxalate, 0.4 M ammonium sulfate, 0.1 M hydroxyl ammonium sulfate and 0.005 M DTPA
pH of electrolyte solution	1.8

ing led to a lower deposition. Above 1.0 M, the equilibrium between deposition and dissolution increasingly favored dissolution. Therefore, at about 0.3 M ammonium oxalate and 0.4 M ammonium sulfate, the deposition shows the least spattering and corrosion.

The distance between the electrodes is not a critical parameter as long as the current is maintained at 950 mA. Darkening of the cathode occurred at a spacing of 2 mm, and excessive voltage was required at a spacing of about 8 mm, resulting in boiling and electrolyte loss. A distance of about 5 mm gave the best plate condition. The optimum conditions of the electrodeposition are summarized in Table 1.

Validation of the electroplating procedure. The optimized electrodeposition method for the analysis of plutonium in environmental samples was validated by its application to several IAEA-Reference soils. As shown in Table 2, the concentrations of plutonium using the optimized electrodeposition step are so consistent with reference values reported by IAEA that we presume that this method can be

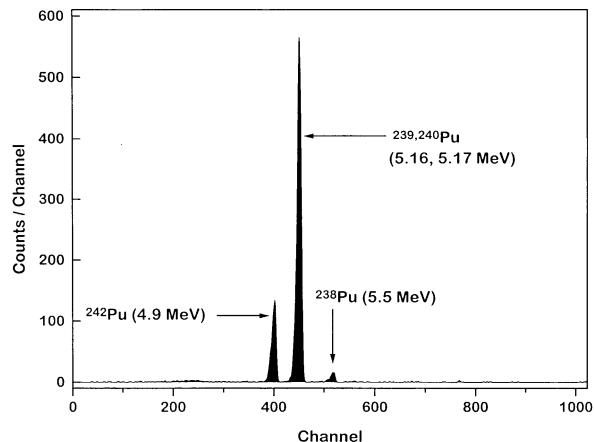

Figure 8. Alpha spectrum of fallout Pu in the IAEA-327 Soil.

applied to different soils with reliable results. Also, Figure 8 shows the typical α -particle spectrum of plutonium fraction isolated from the IAEA-327 Soil using the method described above. The alpha peaks of ²⁴²Pu, ^{239,240}Pu and ²³⁸Pu are well resolved (FWHM; 26.6 keV) and the spectrum is free from contributions due to various thorium and uranium isotopes.

In the determination of plutonium in the environmental sample, it is necessary to prevent iron electrodeposition, because iron contributes to the thickness of the deposit and inhibits the deposition of actinides. Talvitie reported that oxalic acid can be used for additional suppression of iron interference but it also inhibits the deposition of actinides⁹. In this study, the ammonium oxalate was used to prevent the precipitation and inhibit the electrodeposition of iron. The chemical yields obtained for different environmental samples were presented in Table 3. The chemical yield of the optimized method of electrodeposition step was about 7% higher than that of the Talvitie's method. The low chemical yields in the Talvitie's method may arise from the precipitation of iron extracted from sample materials on the stainless steel disk. It means that the ammonium oxalate is rather an effective material for suppression of iron interference than inhibition of the deposition of plutonium.

To remove organic carbon in the routine analysis of Pu in the environmental sample, about 1 mL of HClO₄ and HNO₃ were added to the purified Pu fraction before the electrodeposition. As shown in Table 3, the chemical yields in the Talvitie's method which omitted the removal of organic carbon step were reduced dramatically. However, the effect of organic carbon in the optimized method was less than that in the Talvitie's method.

In Table 4, the electrodeposition yields obtained for the actinides were compared with the modified method and the

Table 2. Concentrations of ^{239,240}Pu for soil reference samples obtained by the 'optimized method'

Sample	Concentration of ^{239,240} Pu (Bq kg ⁻¹)		Concentration of ²³⁸ Pu (Bq kg ⁻¹)	
	Ref. Value	This method ^a	Ref. Value	This method
IAEA-326 Soil	0.495 ± 0.025	0.484 ± 0.031 ^b	0.019 ± 0.002	0.022 ± 0.003
IAEA-327 Soil	0.584 ± 0.018	0.587 ± 0.012	0.020 ± 0.005	0.023 ± 0.006

^aNumber of aliquots analyzed is 3. ^bThe uncertainty is 1 σ

Table 3. Comparison of chemical yields of the optimized method with those of the Talvitie's method

Sample material	Chemical yield in %			
	This method		Talvitie's method	
	Removal of organic ^a	Within organic ^b	Removal of organic ^a	Within organic ^b
Soil(100 kg-dry)	75.3 ± 14.5 ^c	72.4 ± 11.2	65.4 ± 12.7	45.9 ± 10.2
Sediment(100 kg-dry)	70.6 ± 12.7	69.1 ± 10.2	65.1 ± 12.1	58.5 ± 11.1
Moss(20 g-dry)	74.6 ± 18.1	70.4 ± 13.2	70.4 ± 13.4	59.4 ± 11.8

^aNumber of aliquots analyzed is 4. ^bNumber of aliquots analyzed is 2. ^cThe uncertainty is 1σ

Table 4. Comparison of deposition yield and resolution of actinides of the optimized method with those of the Talvitie's method

Actinide	This method ^a		Talvitie's method ^a	
	Deposition yield (%)	FWHM (keV)	Deposition yield (%)	FWHM (keV)
²³² U	96.9 ± 3.3 ^b	27.1	93.1 ± 3.5	27.3
²²⁹ Th	89.4 ± 2.9	26.4	85.5 ± 4.7	26.1
²⁴² Pu	98.6 ± 3.1	26.1	92.4 ± 2.8	25.9
²⁴³ Am	93.8 ± 3.4	26.3	91.9 ± 4.2	26.0

^aNumber of aliquots analyzed is 2. ^bThe uncertainty is 1σ

Talvitie's one. Although the energy resolution of the modified method is similar to the Talvitie's method, the electrodeposition yields of the optimized method of the step were a little higher than that of the Talvitie's method. The reason for the high electrodeposition yield in the optimized method arises from the effect of the chelating agent. DTPA used in this method perhaps suppresses polymerization of the actinides owing to local concentration of ammonium hydroxide during the electrodeposition time. Also, the low recoveries in the Talvitie's method were attributed primarily to a change in pH. As seen in Figure 5, the pH at the cathode increases by discharge of proton from the strong acid such as sulfuric acid at the beginning of the deposition. However, as the deposition is continued for about 2 hours, the weak acids such as the ammonium oxalate, ammonium sulfate and DTPA begin to contribute to formation of proton by dissociation and/or decarboxylation causing the decrease of the pH, and to prevent a significant pH change. However, in the Talvitie's method, the buffer capacity of pH in only the ammonium sulfate electrolyte may be less effective than in

the electrolyte developed in this study. Sometimes, during the pH adjustment with the Talvitie's method, the electrodeposition volume exceeds the adjusted volume (9 mL) so that electrodeposition yield is lower than in this method. Also, the time consumed at the modified electrodeposition method is a little shorter than the processing times of the conventional methods, because this method does not need pH adjustment.

Acknowledgment. This study was carried out under the Nuclear R & D program by Ministry of Science and Technology of Korea.

References

- Dutton, J. W. R.; Lovett, M. B. *Nature* **1977**, 267, 37.
- Hallstadius, L. *Nucl. Instrum. Meth. Phys. Res.* **1984**, 223, 266.
- Liu, S. T.; Ban, Y.; Sumiya, S.; Ishida, J.; Iwai, M. *J. Radioanal. Nucl. Chem. Article* **1988**, 121, 167.
- Tome, F. V.; Sanchez, A. M. *Appl. Radiat. Isot.* **1991**, 42, 135.
- Mitchell, R. F. *Anal. Chem.* **1960**, 32, 326.
- Veselsky, J. C. *Analytica Chimica Acta* **1977**, 90, 1.
- Puphal, K. W.; Olsen, D. R. *Anal. Chem.* **1972**, 44, 284.
- Handley, T. H.; Cooper, J. H. *Anal. Chem.* **1969**, 41, 381.
- Talvitie, N. A. *Anal. Chem.* **1972**, 44, 280.
- Joshi, S. R. *J. Radioanal. Nucl. Chem. Article* **1985**, 90, 409.
- Hindman, F. D. *Anal. Chem.* **1986**, 58, 1238.
- Schüttelkopf, H. *KfK-Report 3035*; 1981.
- Lee, M. H.; Pimpl, M. *Appl. Radiat. Isot.* **1999**, 50, 851.
- Curie, L. A. *Anal. Chem.* **1968**, 40, 586.