

## Z-scan Studies on the Third-order Optical Nonlinearity of Au Nanoparticles Embedded in TiO<sub>2</sub>

Minjoun Kyoung and Minyung Lee\*

Department of Chemistry, Ewha Womans University, Seoul 120-750, Korea

Received September 29, 1999

Nonlinear optical properties of gold nanoclusters have attracted wide attention, owing to their potential use as nonlinear optical devices.<sup>1</sup> In the surface plasmon resonance (SPR) absorption region, the material exhibits large optical nonlinearities and ultrafast time response.<sup>2-5</sup> The SPR peak position of spherically shaped gold particles embedded in dielectrics can be predicted by the Mie theory:

$$\varepsilon_1(\omega_s) + 2\varepsilon_m(\omega_s) = 0 \quad (1)$$

where  $\varepsilon_1$  is the real part of the dielectric constant of the metal particle, and  $\varepsilon_m$  the dielectric constant of the surrounding dielectrics, and  $\omega_s$  the surface plasmon resonance frequency.<sup>1</sup>

The peak position of the SPR absorption band of Au nanoclusters in common SiO<sub>2</sub> glass ( $\varepsilon \approx 2.3$ ) occurs around 520 nm. As the dielectric constant of the matrix increases, the SPR band is shifted to the longer wavelength. There have been numerous reports on the linear and nonlinear optical properties of Au particles in SiO<sub>2</sub> matrices.<sup>6,7</sup> However, related studies in TiO<sub>2</sub> are rare,<sup>8</sup> owing to difficulties in preparation. Titanium oxide material has been known to possess a much larger  $\varepsilon$  value, compared to the silica glass. Therefore, the optical properties of Au:TiO<sub>2</sub> composites are expected to be much different from Au:SiO<sub>2</sub>. Recently, using the sol-gel and high temperature annealing technique, we have prepared Au nanoparticles embedded in TiO<sub>2</sub> thin films and reported some interesting characteristics of composite films, using X-ray, TEM and optical methods.<sup>9</sup> As shown in Figure 1, the peak of the SPR spectrum of gold nanoparticles in TiO<sub>2</sub> occurs at 647 nm. The crystalline form of the titania matrix is anatase, having the dielectric constant value of 6.2. Therefore, the SPR band is red-shifted by 130 nm, compared to Au particles in SiO<sub>2</sub> matrix. Another interesting feature observed for Au:TiO<sub>2</sub> composites was that the peak is much broadened than expected, due to spatial spreading and scattering of electron, which contributes to the plasmon absorption across the particle-matrix interface.<sup>1</sup>

In this work, we report the nonlinear optical properties of a sol-gel-processed Au:TiO<sub>2</sub> thin film by using the Z-scan method. The Z-scan measures the normalized transmittance as a function of laser intensity with moving the sample through the focal plane of a lens. The normalized Z-scan transmittance is given by<sup>10</sup>

$$T(z) = \frac{\int_{-\infty}^{\infty} P_T(\Delta\Phi_0(t))dt}{S \int_{-\infty}^{\infty} P_i(t)dt} \quad (2)$$

where  $P_i$  is the instantaneous input power and  $S$  is the aperture linear transmittance.  $P_T$  is the transmittance power through the aperture, which is a function of the phase distortion  $\Delta\Phi_0$ . The analytical form for Eq. (2) is not known and thus an extensive computational procedure is necessary to obtain the theoretical Z-scan transmittance. The normal procedure of obtaining the nonlinear optical coefficients of a sample by the Z-scan is that one measures experimentally the Z-scan transmittance and fit the data to Eq. (2). The fitting parameters are the nonlinear refractive index, together with the multiphoton absorption or saturation absorption coefficient, if the processes are accompanied.<sup>11</sup> The Z-scan method also gives us the sign of the nonlinear refractive index and absorption, as well as the magnitude.

The experimental setup for the Z-scan measurement was shown in Figure 2. A femtosecond mode-locked Ti:sapphire laser system operating at 800 kHz was used as the light source. The laser pulsewidth measured by an autocorrelator was 250 fs, assuming the sech<sup>2</sup> pulse shape. The beam diameter at the output is *ca.* 2 mm having the TEM<sub>00</sub> mode. To increase the beam irradiance at the sample, the laser beam was first enlarged by a beam expander and was focussed into the sample with a 10 cm lens. The beam size was measured by scanning a 1.0  $\mu\text{m}$  pinhole transversely at the beam waist and by fitting the measured intensity profile to a Gaussian function. The obtained beam radius was 8.3  $\mu\text{m}$ . The peak intensity on the spot was maintained as 5.6 GW/cm<sup>2</sup>. The optical density and the linear absorption coefficient are 0.38 and  $2.9 \times 10^4 \text{ cm}^{-1}$  at 750 nm, respectively.

The Z-scan was first conducted for a blank sample in which the TiO<sub>2</sub> film does not contain Au particles, and no transmittance change was observed at the beam intensity of 5.6 GW/cm<sup>2</sup>. With maintaining the same intensity, the Z-scan measurement was performed for the Au:TiO<sub>2</sub> thin film. Figure 3 shows the Z-scan data with the closed aperture size ( $S$ ) of 0.3. The peak-to-valley profile displayed in Figure 3 demonstrates that the sample exhibits a self-defocusing effect, *i.e.*, it has a negative nonlinearity at 750 nm. It contains contributions from both of the nonlinear saturation absorption and the nonlinear refractive index. The saturation absorption enhanced the peak and diminished the valley of the transmittance. The absorption coefficient under saturation is given by<sup>11,12</sup>

\*To whom correspondence should be addressed. Tel: +82-2-3277-2383, Fax: +82-2-3277-2384, E-mail: mylee@mm.ewha.ac.kr

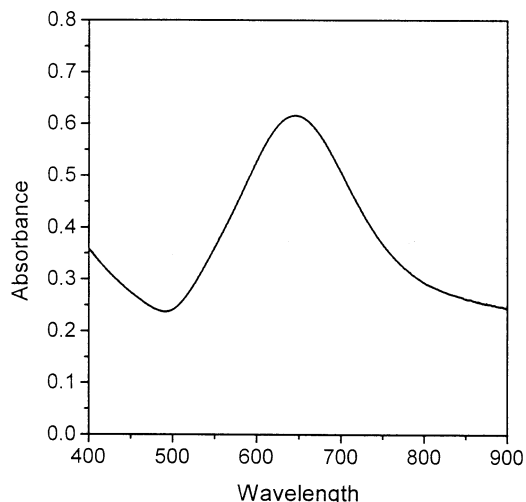

**Figure 1.** Absorption spectrum of Au nanoparticles in TiO<sub>2</sub> prepared by sol-gel processing and by high temperature annealing at 700 °C. The average particle diameter of 25 nm has been measured by TEM. The film thickness is *ca.* 115 nm.

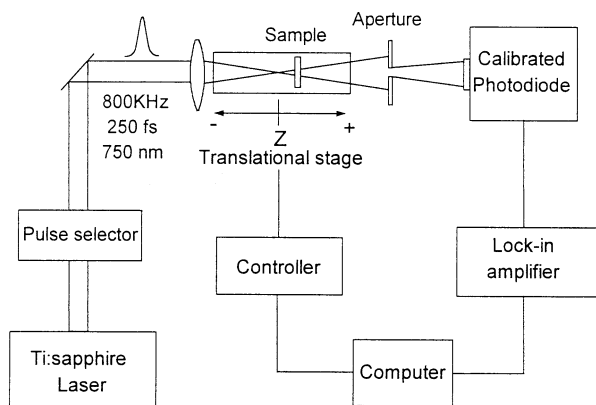

**Figure 2.** Schematic diagram for the Z-scan experimental setup.

$$\alpha = \frac{\alpha_0}{1 + I/I_s}, \quad (3)$$

where  $\alpha_0$  is the linear absorption coefficient in the absence of saturation,  $I_s$  is the saturation intensity. In the weak saturation limit, *i.e.*,  $I/I_s \ll 1$ , Eq. (3) is reduced to

$$\alpha \approx \alpha_0(1 - I/I_s) = \alpha_0 - \frac{\alpha_0}{I_s}I = \alpha_0 + \Delta\alpha I \quad (4)$$

We obtained the saturation intensity ( $-\alpha_0/I_s$ ) from the fitting by using Eq. (1) with the open aperture ( $S = 1$ ) data which has a maximum transmittance at the focus. The value is  $-1.48 \times 10^3$  cm/GW. To calculate the value of the nonlinear refractive index, the closed aperture ( $S=0.3$ ) data were fitted to Eq. (2). The solid curve in Figure 3 was obtained by fitting the data points with  $\gamma = -9.8 \times 10^{-2}$  cm<sup>2</sup>/GW, where  $\gamma$  is the real part of the nonlinear refractive index. In the case of saturation absorption,  $n_2$  is a complex number which has a real and an imaginary part,<sup>11</sup>

$$n_2 = \gamma + i \frac{c\Delta\alpha}{2\omega} = \gamma - i \frac{c\alpha_0}{2\omega I_s} \quad (5)$$

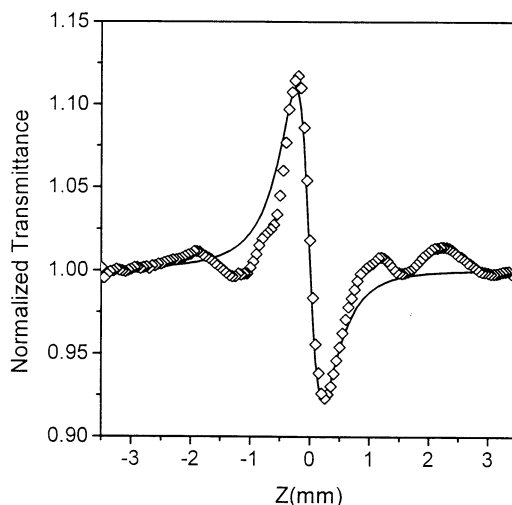

**Figure 3.** The closed aperture ( $S=0.3$ ) Z-scan data for Au-TiO<sub>2</sub> composite. The solid curve is a fit to the data using the Z-scan theory.

The real part of  $\chi^{(3)}$  is related to  $\gamma$  by

$$Re\chi^{(3)} = \frac{cn_0^2}{16\pi^2}\gamma \quad (6)$$

and the imaginary part is related to the change of the absorption coefficient  $\Delta\alpha$

$$Im\chi^{(3)} = -\frac{cn_0^2 c\alpha_0}{32\pi^2 \omega I_s} \quad (7)$$

Using the Eq. (5) and (6), we obtained  $Re\chi^{(3)} = -1.11 \times 10^{-7}$  esu and  $Im\chi^{(3)} = -2.07 \times 10^{-8}$  esu. Both the real and the imaginary part of  $\chi^{(3)}$  are negative. This corresponds to the absolute  $\chi^{(3)}$  value of  $1.13 \times 10^{-7}$  esu. The  $\chi^{(3)}$  value of Au nanoparticles in sol-gel-processed silica glass has been previously measured as an order of  $10^{-8}$  esu at 532 nm.<sup>4</sup>

The  $\chi^{(3)}$  value is proportional to the fourth power of the local field factor  $f_i$ .<sup>5,8,13</sup> Under resonance condition [Eq. (1)], the local field factor is given by  $f_i = 3\epsilon_m/i\epsilon_2$ , where  $\epsilon_2$  is the imaginary part of the metal dielectric constant. The absolute value of the local field factor for Au:TiO<sub>2</sub>(anatase) is 14.6 at 750 nm, which is five times larger than that of Au:SiO<sub>2</sub> at 520 nm ( $|f_i| = 2.9$ ). This means that, by changing the dielectric medium, the nonlinear optical coefficient of Au nanoparticles can be increased by more than two orders of magnitude. Our measured  $\chi^{(3)}$  value showed only a ten-fold enhancement, indicating that the volume fraction of gold nanoclusters in TiO<sub>2</sub> is much smaller than that in SiO<sub>2</sub>.

In summary, the nonlinear optical properties of Au:TiO<sub>2</sub> composites have been studied, using the Z-scan technique. The sample exhibits a self-defocusing and saturation at the input power of 5.6 GW/cm<sup>2</sup>. The sign and magnitude of  $\chi^{(3)}$  was obtained by fitting the Z-scan data to the theory. The large enhancement for the third-order optical nonlinearity of Au:TiO<sub>2</sub> composites was described by taking into account the local field factor.

**References**

1. See, for example, Kreibig, U.; Vollmer, M. *Optical Properties of Metal Clusters*; Springer: Berlin, 1993.
  2. Yang, L.; Becker, K.; Smith, F.; Marguder III, R. H.; Haglund, R. F., Jr.; Yang, L.; Dorsinville, R.; Alfano, R. R.; Zuhr, R. A. *J. Opt. Soc. Am. B* **1994**, *11*, 457.
  3. Hache, F.; Ricard, D.; Flyzannis, C.; Kreibig, U. *Appl. Phys. A* **1988**, *47*, 347.
  4. Lee, M.; Kim, T. S.; Choi, Y. S. *J. Non-Cryst. Solids* **1997**, *211*, 143.
  5. Haglund, R. F., Jr.; Yang, L.; Magruder III, R. H.; Wittig, J. E.; Becker, K.; Zuhr, R. A. *Opt. Lett.* **1993**, *18*, 373.
  6. Lio, H. B.; Xiao, R. F.; Fu, J. S.; Yu, P.; Wong, G. K. L.; Sheng, P. *Appl. Phys. Lett.* **1997**, *70*, 1.
  7. Inouye, H.; Tanaka, K.; Tanahashi, I.; Hirao, K. *Jpn. J. Appl. Phys.* **1998**, *37*, 1520.
  8. Uchida, K.; Kaneko, S.; Omi, S.; Hata, C.; Tanji, H.; Asahara, Y.; Ikushima, A. *J. Opt. Soc. Am. B* **1994**, *11*, 1236.
  9. Lee, M.; Chae, L.; Lee, K. C. *Nanostructured Materials* **1999**, *1*, 195.
  10. Sheik-bahae, M.; Said, A. A.; Wei, T-H.; Hagand, D. J.; Van. Stryland, E. W. *IEEE* **1990**, 760.
  11. Yang, L.; Dorsinville, R.; Wang, Q. Z.; Ye, P. X.; Alfano, R. R.; Zamboni, R. Taliani, C. *Opt. Lett.* **1992**, *17*, 323.
  12. Sutherland, R. L. *Handbook of Nonlinear Optics*; Marcel Dekker, Inc.: New York, Basel, Hong Kong, 1996.
  13. Bloemer, M. J.; Hans, J. W.; Ashley, P. R. *J. Opt. Soc. Am. B* **1990**, *7*, 790.
-