

Computer-aided design of nano-filter construction using DNA self-assembly

Reza Mohammadzadegan · Hassan Mohabatkar

Published online: 9 November 2006
© to the authors 2006

Abstract Computer-aided design plays a fundamental role in both top-down and bottom-up nano-system fabrication. This paper presents a bottom-up nano-filter patterning process based on DNA self-assembly. In this study we designed a new method to construct fully designed nano-filters with the pores between 5 nm and 9 nm in diameter. Our calculations illustrated that by constructing such a nano-filter we would be able to separate many molecules.

Keywords Computer-aided design · Nano-filter · DNA · Self-assembly

Introduction

Since the introduction of the idea that nucleic acids could be used to synthesize nanoscale grids and lattice structures the development of DNA (Deoxyribonucleic acid) self-assembly into a practical method for creating nanoscale circuit patterns has garnered increasing support [1–3]. However, the exotic nature of DNA self-assembly as compared to conventional photolithography introduces new challenges for system designers and Computer-aided design (CAD) tool makers.

Electronic Supplementary Material Supplementary material is available to authorised users in the online version of this article at <http://dx.doi.org/10.1007/s11671-006-9024-6>

R. Mohammadzadegan (✉) · H. Mohabatkar
Department of Biology, College of Sciences, Shiraz
University, Shiraz, Iran
e-mail: admin@nanodetails.com

Clean water and environment are the most critical aspects of human life. Human kind is exposed to pathogenic bacteria and viruses. These bacteria and viruses are present all around the world. The bacterial length varies from 1 μ to 20 μ . Where as, viruses are smaller; their length vary from 30 nm to 0.5 μ [4]. The ability of filtering environment is very important in epidemiological disasters. Additionally in engines, clean oil is vital to keep them running properly. In order to remain effective oil must be filtered as it cycles. Our CAD nano-filter method would be able to separate unwanted materials in the oil.

The “bottom-up” approach to nanotechnology, self-assembly of molecules is highly desirable, because it can permit the formation of large networks with relative ease [3, 5–7]. DNA is an excellent molecule for the formation of macromolecular networks because it is easy to synthesize. It has four major features: molecular recognition, self-assembly, programmability, and predictable nanoscale structure [3, 8, 9].

DNA is organized as two complementary strands, with the hydrogen bonds between them. Each strand of DNA is a chain of chemical “building blocks”, called nucleotides, of which there are four types: adenine (A), cytosine (C), guanine (G) and thymine (T). Between the two strands, each base can only “pair up” with one single predetermined base: A + T, T + A, C + G and G + C are the only possible combinations. Two nucleotides paired together are called a base pair [10–14].

Because of the importance of construction the fully designed nano-filter (NF) we aimed to design a new filtration method based on DNA nanotechnology. In the present work, we designed DNA nano-filters with the pores between 5 nm and 9 nm in diameter.

Backgrounds and methods

The design of branched nucleic acid motifs is based on the notion of maximizing the base pairing. The system illustrated in Fig. 1a maximizes the base pairing between its four component strands by forming the structure shown. Binding together with the other in addition to having strands that are completely paired with one another, it is also possible to have one strand a little longer than its complement, leading to an overhang. This

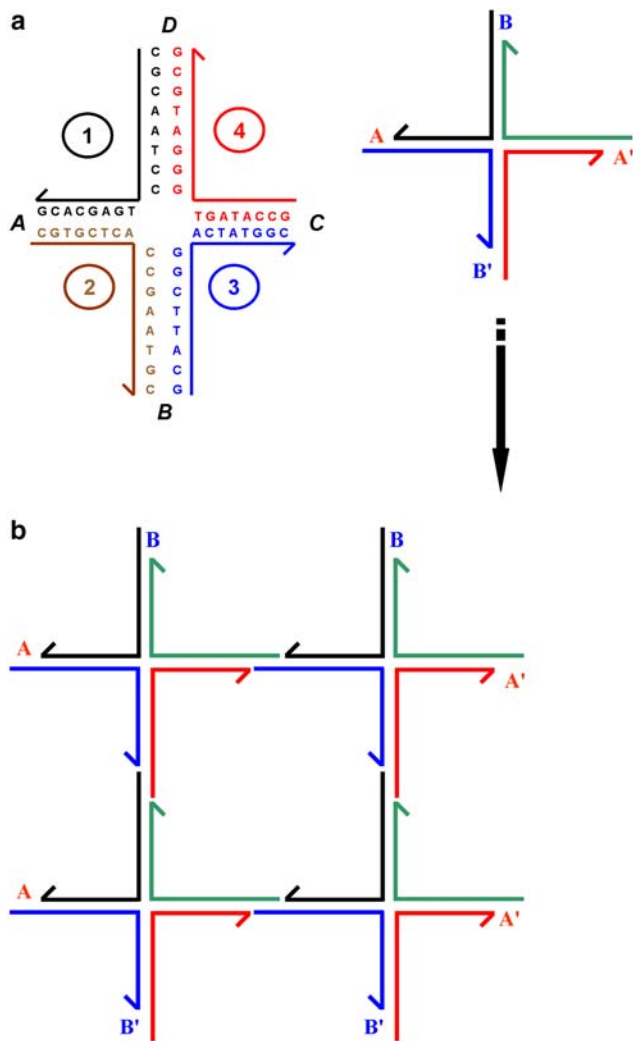

Fig. 1 (a) A branched molecule with four arms. Four strands labeled with numbers 1–4 combine to produce four arms, labeled with Alphabets A–D. Arrowheads indicate strand polarity. (b) Formation of a two-dimensional lattice from a four-arm junction with sticky ends. A is a sticky end and A' is its complement. The same relationship exists between B and B'. Four of the monomeric junctions on the top-right are complexes in parallel orientation to yield the structure on the bottom. Note that the complex has maintained open valences, so it could be extended by the addition of more monomers. This image is designed due to Ref. [16]

overhang, called a “sticky end”. It is possible to direct branched molecules to associate by using sticky ends. This idea is shown in Fig. 1b. What this figure shows is a self-assembly process directed by the complementary sequences on the sticky ends [15–18].

In the present work, we based our designing on using DNA single strands and their efficient capability to bind to their complementary strands. Designed hexagonal and octagonal networks are shown in Fig. 2a and c.

Our results

Designing the sequences

The hexagonal network

General. In our work sticky ends are typically 5 bases long, and cohere with good fidelity; the ability to direct cohesion through sticky-ended complementarity is straightforward. However, there is a second key feature to sticky-ended cohesion: sticky ends form B-DNA (common form of DNA in physiological medium) when they bind to each other, so that the local geometry of the cohesive system is known without performing a new experiment (e.g. a crystal

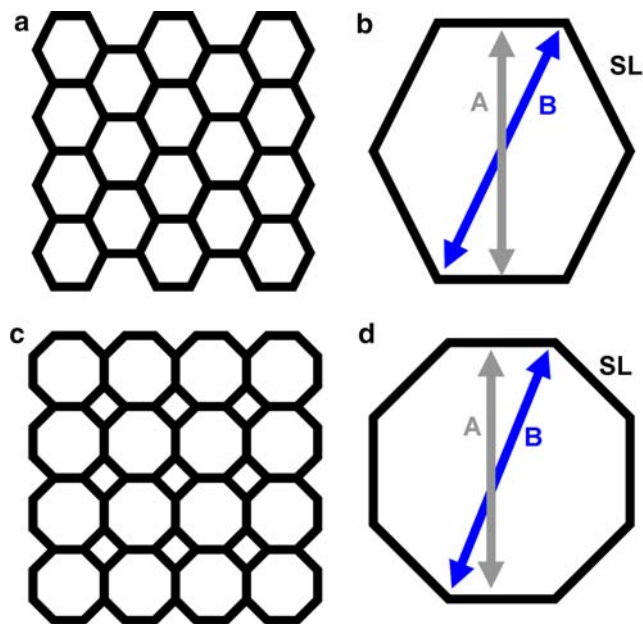

Fig. 2 (a) A hexagonal network; constructed of 3 different complementary strands. (b) Calculation of each pore diameter. Whereas $A = SL\sqrt{2}$, and $B = SL\sqrt{3}$. (c) An octagonal network; constructed of 5 different complementary strands. (d) Calculation of each pore diameter. Whereas $A = SL(1 + \sqrt{2})$, and $B = 2SL\sqrt{1 + \sqrt{2}}$.

structure determination) every time a new sticky end is designed. Thus, the use of sticky ends is convenient because the intermolecular structures formed are predictable, since complementarity is easy to program.

Sequences. In hexagonal network the designed sequences are:

- A: 5'-ATACTCACTACCCTCGATCA-3'
 B: 5'-GTACGAGTATATTCCGAGGG-3'
 C: 5'-TAGTGCCTACTGATCGGAAT-3'

Pore size calculation. Likewise what we discussed previously, it is very likely that complementary sequences bind each other and the result is the construction of a network which is the NF. Each single strand constitutes of 20 bases, therefore its length is 20×0.34 nm or 6.8 nm. As it is shown in Fig. 2b the height of each pore is dependent on A and B arrows length. While the straight length of each strand (SL) is 10 bases long, SL will be 3.4 nm. Thus A and B are 4.8 and 5.89 nm respectively. So molecules larger than 5.9 nm in length are limited by this network.

The octagonal network

Sequences. In octagonal network construction, the designed DNA blocks sequences are:

- A: 5'-ATTCGCTCGATGCGCATTCG-3'
 B: 5'-TGCACACTCGTAGTATGCCT-3'
 C: 5'-GCGTAGCGCATCGAGGCCTT-3'
 D: 5'-TTAGTTACTACGAGTTTACG-3'
 E: 5'-ACTAAAAGGCCGAATCGTAAGTGAC
 GAATTACGCAGGCA-3'

where as E is the supporter single strand.

Pore size calculation. Each main single strand (A–D) constitutes of 20 bases, therefore its length is 6.8 nm. As it is shown in Fig. 2d the height of each pore is dependent on A and B arrows length, 8.2 nm and 8.88 nm, respectively. So molecules larger than 8.9 nm in length are limited by this network.

Sequences analysis

Sequences quality analysis. In both cases of designing the sequences of hexagonal and octagonal block strands the software BioEdit was used to measure the efficiency of those sequences, aligning and blasting of sequences were performed, the less score and the less identity the more fitness (Data are shown in Table 1 of supplementary data) [19–22]. The results obtained indicated that those sequences were in good harmony with each other. And their coherence was in good

fidelity. Subsequently, the valuable data is that there would be no interferences between the sequences.

The linker sequences

General. Additionally one can use some chemical modifiers with special sequences of DNA which can bind to surfaces and the complementary strands in the network to stabling the network in the medium. Liu et al. [23] accomplished the placement of single-stranded DNA onto a gold surface via sulfur, after removing a self-assembled resist pattern by AFM. Some other scientists have been bound DNA to metal substrates using DNA end modifications [24–29]. By using this feature and designing the sequences of sticky ends one can bind the network to the proper position of the supporter frame, in order to making the stable NF. Thus we designed the proper sequence for the linker single strand DNAs. Like the prior designations, the linker sequences designed, blasted and aligned with each other and with other sequences to gain the best result.

Linker sequences for hexagonal network. Designed linkers for hexagonal network are:

- I: 5'-HS-(CH₂)₆-TTCCGGCTAAGAGGG-3'
 II: 5'-TAGTGTTAGCCGGAA-3'
 III: 5'-HS-(CH₂)₆-TTCCGGCTAA-3'
 IV: 5'-HS-(CH₂)₆-TTCCGGCTAACGTACT
 GATC-3'
 V: 5'-AGTATATTCCTTAGCCGGAA-3'
 VI: 5'-HS-(CH₂)₆-TTCCGGCTAACAC
 TACCCTCTTAGCCGGAA-3'

Linker sequences for hexagonal network. Designed linkers for octagonal network are:

- I: 5'-HS-(CH₂)₆-TTTTCCCTTACTCGATGCGC
 TAAGGGAAAA-3'
 II: 5'-HS-(CH₂)₆-TTTTCCCTTAGCGCATCGAG
 TAAGGGAAAA-3'
 III: 5'-HS-(CH₂)₆-TTTTCCCTTAACTCGTAGTA
 TAAGGGAAAA-3'
 IV: 5'-HS-(CH₂)₆-TTTTCCCTTATACTACGAGT
 TAAGGGAAAA-3'
 V: 5'-HS-(CH₂)₆-TTTTCCCTTA-3'

Molecular size prediction

QSAR properties. Another task of us was to calculate sizes of some important molecules of toxins, oil and soil media. The molecules were drowned and their geometrical conformations were fitted. Then their approximate lengths were calculated using QSAR

(quantitative structure–activity relationship) [30–32]. The surface distances between two farthest atoms of molecules were calculated; also we calculated the volume of each whole molecule (data are shown in Table 2 of supplementary data).

Molecular filterability prediction. Using these data and the calculated diameter of NF pores we can claim that our designed network would be able to filter some of those mentioned molecules (See Table 2 of supplementary data).

Discussion

In this study, we designed a new method to construct fully designed nano-filters using DNA nanotechnology. Our calculations illustrated that by constructing such a NF we would be able to separate many molecules. The NF designed in this work is capable to filter bacteria and viruses in critical epidemiological conditions. Using DNA NFs in oil and water filtration would be helpful to purify and clean them. These criteria would be valuable in environmental catastrophes and prevention of environmental pollutions. The schematic designs of both Hexagonal and Octagonal networks which have been bound to the frames are present at Fig. 3a and b of supplementary data.

The designed NF can reject also ions with one or more positive charge, such as Ag, Au, Cu, Mn, and Mg and so on, while passing charged ions. Additionally covering the network with metallic nano-particles (e.g., Ag [24, 26, 33, 34], Pd [35], Pt [29], Cu [36] and Au [37]) would lead to stabilization of the network against the medium.

Acknowledgments This work was supported by Shiraz University. The authors would like to thank Dr. Mohammad Hossein Sheikhi, Prof. Afsaneh Safavi, Prof. Mahmood Barati-Khajooie, Dr. Ali Amiri and Mr. Babak Saffari for their helpful comments on the manuscript.

References

- N.C. Seeman, J. Theor. Biol. **99**, 237 (1982)
- B.H. Robinson, N.C. Seeman, Protein Eng. **4**, 295 (1987)
- N.C. Seeman, Nature **421**, 427 (2003)
- D. Davis, R. Dulbecco, H.N. Eisen, H.S. Ginsberg Microbiology (J.B. Lippincott-Pennsylvania, 1990 [ISBN 0397506899])
- C. Dwyer, S.H. Park, T.H. LaBean, A.R. Lebeck, *Foundations of Nanoscience: Self-Assembled Architectures and Devices* (Snowbird, Utah, 2005), pp. 187–191
- A. Carbone, N.C. Seeman, Circuits and programmable self-assembling DNA structures. Proc. Natl. Acad. Sci. **99**, 1 (2002)
- M.A. Batalia, E.R.B. Protozanova, R.B. Macgregor Jr., D. Erie, Nano Lett. **2**, 269 (2002)
- P.W.K. Rothmund, Presented at IEEE/ACM International Conference on Computer Aided Design (ICCAD) (2005)
- U. Feldkamp, S. Saghafi, W. Banzhaf, H. Rauhe, *Proceedings of the Seventh International Workshop on DNA Based Computers (DNA7) 2340* (2001), p. 23
- J.D. Watson, F.H.C. Crick, Nature **171**, 737 (1953)
- J.D. Watson, DNA: The Secret of Life (Knopf 2003 [ISBN 0375415467])
- J.D. Watson, The Double Helix: A Personal Account of the Discovery of the Structure of DNA (Signet 1969 [ISBN 0451627873])
- S. Chomet, DNA Genesis of a Discovery (Newman-Hemisphere Press, London, 1994)
- K.R. Miller, J. Levin, Biology (Pearson Prentice Hall-New Jersey, 2003 [ISBN 013036701X])
- H. Qiu, J.C. Dewan, N.C. Seeman, J. Mol. Biol. **267**, 881 (1997)
- N.C. Seeman, Mater. Today **1**, 24 (2003)
- C.A. Mirkin, R.L. Letsinger, R.C. Mucic, J.J. Storhoff, Nature **382**, 607 (1996)
- A.P. Alivisatos, K.P. Johnsson, X. Peng, T.E. Wilson, C.J. Loweth, M.P. Bruchez Jr., P.G. Schultz, Nature **382**, 609 (1996)
- T.F. Smith, M.S. Waterman, J. Mol. Biol. **147**(1), 195 (1981)
- E.W. Myers, W. Miller, Comput. Appl. Biosci **4**(1), 11 (1988)
- O. Gotoh, J. Mol. Biol. **162**(3), 705 (1982)
- S.B. Needleman, C.D. Wunsch, J. Mol. Biol. **48**(3), 443 (1970)
- M. Liu, N.A. Amro, C.S. Chow, G. Liu, Nano Lett. **2**(8), 863 (2002)
- E. Braun, Y. Eichen, U. Sivan, G. Ben-Yoseph, Nature **391**, 775 (1998)
- I. Willner, Science **298**, 2407 (2002)
- K. Keren, M. Krueger, R. Gilad, G. Ben-Yoseph, U. Sivan, E. Braun, Science **297**(5578), 72 (2002)
- T.G. Drummond, M.G. Hill, J.K. Barton, Nat. Biotechnol. **21**(10), 1192 (2003)
- R.P. Fahlman, D. Sen, J. Am. Chem. Soc. **124**(17), 4610 (2002)
- M. Mertig, L.C. Ciacchi, R. Seidel, W. Pompe, A. De Vita, Nano Lett. **2**(8), 841 (2002)
- E.K. Freyhult, K. Andersson, M.G. Gustafsson, J. Biophys. **84**, 2264 (2003)
- F. Yoshida, J.G. Topliss, J. Med. Chem. **43**(13), 2575 (2000)
- D.M. Hawkins, S.C. Basak, X. Shi, J. Chem. Inf. Comput. Sci. **41**(3), 663 (2001)
- K. Keren, R.S. Berman, E. Buchstab, U. Sivan, E. Braun, Science **302**(5649), 1380 (2003)
- Z.X. Deng, C.D. Mao, Angew. Chem. Int. Ed. Engl. **43**(31), 4068 (2004)
- J. Richter, R. Seidel, R. Kirsch, M. Mertig, W. Pompe, J. Plaschke, H.K. Schackert, Adv. Mater. **12**(7), 507 (2000)
- C.F. Monson, A.T. Woolley, Nano Lett. **3**(3), 359 (2003)
- G. Braun, K. Inagaki, R.A. Estabrook, D.K. Wood, E. Levy, A.N. Cleland, G.F. Strouse, N.O. Reich, Langmuir **21**(23), 10699 (2005)